

NOTICE INVITING QUOTATION FOR

NAME OF THE WORK

**Fabrication of Light Goods Vehicles (LGV)
(Mahindra Supro Mini Profit Truck VX BS 6.2)
(Newly Purchased)**

**SUFAL BANGLA
PROJECT MANAGEMENT UNIT
Under**

**PASCHIMBANGA AGRI MARKETING CORPORATION LIMITED
2nd Floor, Uttarapan Civic Centre
Maniktala, kolkata-700 054**

WEST BENGAL

2024-2025

Project Director
SUFAL BANGLA

INDEX

SI.NO	CONTENT	PAGE NO
Section-1	LIST OF IMPORTANT DATES	1
Section-2	NOTICE INVITING E-QUOTATION	2-8
Section-3	QUALIFICATION INFORMATION	9
Section-4	QUALIFICATION APPLICATION	10-13
Section-5	LETTER OF ACCEPTANCE	14
Section-6	INSTRUCTION TO BIDDERS	15-16
Section-7	AGREEMENT	17-18
Section-8	CHECK LIST FOR BIDDERS	19-20
Section-9	GENERAL INSTRUCTIONS TO BIDDERS	21-22

Project Director
SUFAL BANGLA

PRESS NOTICE

The Project Director, Sufal Bangla under Paschimbanga Agri Marketing Corporation Ltd invites item rate (inclusive of all taxes) quotation from eligible Fabricator who are working as a body builder of goods vehicle up to 03.00 PM on 28/02/2025 for the following works.

Name of Work & NIQ No.	Earnest Money	Time Allowed for completion	Last date and time for download of quotation document	Time and date of opening of Quotation (ONLINE)	Place of availability of documents (online)
[1].	[2].	[3].	[4].	[5].	[6]
Fabrication of Light Goods Vehicles (LGV)(Mahindra Supro Mini Profit Truck VX BS6.2) (Newly Purchased) NIQ No: PD/PMU/SB/78/2024-25 Dated 19/02/2025	₹ 19,194/-	15 Days	28/02/2025 up to 03.00 PM	(a) Technical bid 03/03/2025 at 01.00 pm or there after (b) Financial bid: Date of opening of Financial Bid will be declared at the time of uploading final findings of technical evaluation.	https://wbtenders.gov.in

(i) The Earnest Money (Refundable) should be deposited by Net Banking / NEFT & RTGS through ICICI Bank Payment Gateway webpage in terms of Order No 3975- F(Y), Dated 28th July 2016 of Finance Dept. Govt. of WB.

Project Director
Sufal Bangla

Project Director
SUFAL BANGLA

SECTION 1

LIST OF IMPORTANT DATES PRESS NOTICE INVITING QUOTATIONS

LIST OF IMPORTANT DATES

1. Name of work: Fabrication of Light Goods Vehicles (LGV)(Mahindra Supro Mini Profit Truck VX BS6.2) (Newly Purchased)
2. Completion Period for work: **15 Days**, countable from the very date of receiving the Work Order by the selected Bidder.
3. Date of Issue of Notice Inviting Bid: 19/02/2025
4. Period of Downloading of Bidding Documents: From 06.00 PM 19/02/2025 to 03.00 PM 28/02/2025
5. Time, Date and Place of Pre-bid Meeting: Date 24/02/2025
Time 12:30 P.M.
Place: **Sufal Bangla, Project Management Unit
2nd Floor, Uttarapan Civic Centre, Maniktala
Kol-700054**
6. Deadline for Submission of Bids : Date: 28/02/2025
Time: 03.00 PM
7. Time and Date for Opening Technical Bid/Bids (ONLINE) : 03/03/2025
Time **01:00 PM or thereafter**
8. Time and Date of Opening Financial Bids (ONLINE): Date of opening of Financial Bid will be declared at the time of uploading final findings of technical evaluation.
9. Place of Opening Bids (ONLINE): Address is:**Sufal Bangla, Project Management Unit
2nd Floor, Uttarapan Civic Centre, Maniktala
Kol-700054**
10. Last Date of Bid Validity: Date: 27.08.2025
12. Officer Inviting Bids Designation: **Project Director, SUFAL BANGLA
PROJECT MANAGEMENT UNIT, 2nd Floor,
Uttarapan Civic Centre,Maniktala, Kolkata-054**

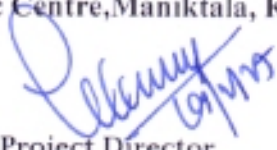
Project Director
SUFAL BANGLA

Project Director
SUFAL BANGLA

Section-2
Notice Inviting e-Quotation
NIQ No: PD/PMU/SB/78/2024-25 Dated 19/02/2025

The Project Director, Sufal Bangla under Paschimbanga Agri Marketing Corporation Ltd invites e-Quotation (inclusive of all taxes) for the following work from the experienced and resourceful Fabricator who are working as a body builder of goods vehicle having at least 5 (Five) years' experience in similar nature of work as detailed in the table below. (Submission of Quotation is to be made online through the website).

Sl. No	Name of the Work	Amount of Earnest Money to be deposited	Period of Completion of the Work	Name & Address of the concerned Employer
1.	Fabrication of Light Goods Vehicles (LGV) (Mahindra Supro Mini Profit Truck VX BS6.2) (Newly Purchased)	₹ 19,194/-	14 Days	Project Director, SUFAL BANGLA, PROJECT MANAGEMENT UNIT, 2nd Floor, Uttarapan Civic Centre Maniktala, kolkata-700 054

PART-A

1. Necessary Earnest Money (as mentioned before) will be deposited by the bidder electronically as per Order No. 3975-F(Y) dated 28th July, 2016 of Finance Department, Government of West Bengal. Bidders are also advised to submit EMD of their bid, at least 3(three) working days before the bid submission closing date as it may require time for processing of payment of EMD.
2. In case of EMD exemption (if any), prayer for exemption from making payment of Earnest Money is to be uploaded in the Portal enclosing therewith document(s) to establish that the bidder is lawfully entitled to get such exemption. **Bidders are asked to follow the rules in regard to exemption of EMD in terms of G.O. No. 4245-F(Y), Dated: 28.05.2013 read with G.O. no. 6142-F(Y), Dated: 10.10.2012. Unsuccessful bidders will get their refund of EMD automatically online.**
3. In case of Partnership Firm(s), the pledged instrument(s) must reflect the name(s) of the firm as well as the name(s) and the address (es) of the partner/partners who is/are authorised to pledge the same as per valid Partnership Deed(s) for claiming EMD exemption.
4. Both Technical Bid and Financial Bid should be submitted duly digitally signed by the Quotationer through the website <https://wbtenders.gov.in>.

5. Scope of Work:

CANOPY STRUCTURE FABRICATION:

- i) **M.S. structural works with hollow sections**
 - ii) **Priming one coat on steel or other metal surface with synthetic oil bound primer of approved quality including smoothening surfaces by sand papering etc**
 - iii) **Painting with best quality synthetic enamel paint of approved make and brand including smoothening surface by sand papering etc. including using of approved putty etc. on the surface, if necessary**
 - iv) **To and fro Transportation of Vehicles**
- For details of work and drawing, please see **Annexure-A**

**Project Director
SUFAL BANGLA**

6. **Eligibility criteria for participation in the Quotation:-**

The intending bidder must submit following documents as a part of their eligibility.

- a) **Credential:** Interested bidder shall have to submit Experience Certificate duly issued by the employer of at least **ONE** completed work of similar nature of value not less than **Rs. 3.83885 Lakh (Rupees Three Lakh Eighty Three Thousand Eight Hundred Eighty Five)** or **TWO** completed works of similar nature of value not less than **Rs. 2.87914 Lakh (Rupees Two Lakh Eighty Seven Thousand Nine Hundred Fourteen Only)** done by the bidder during last 5 (Five) years prior to the issuance of this Notice.
- b) Certificate of Incorporation / Registration and/or Memorandum of article of the agency.
- c) Professional Tax Registration Certificate, GST Registration Certificate with latest GST Return , Valid updated Trade License, Current Professional Tax Challan, Acknowledgement Receipt or current Professional Tax payment Certificate (PTPC).
- d) PAN Card as allotted by the Income Tax Department.
- e) Income Tax return of Financia Year 2020-21, 2021-22 & 2022-23.
- f) Proof of last 5(Five) years experiences for similar type of jobs in Govt/Govt. Undertaking bodies and / or reputed private organization. **In case of Private Organizations, Tax Invoice/Purchase Order of products must be uploaded in portal along with other uploaded documents.**
- g) In case of Company, the following details are to be provided by the bidders in prescribed format:
 - i. Director Identification Number(s) (DIN) of the Director(s) of the Company must be provided.
 - ii. Name of other Companies (if any) having with same DIN must be provided along with GSTIN of the saidcompanies.

Prescribed Format		
1)	Director Identification Number(s) (DIN)	
2)	Name of other companies with the same DIN	
3)	Corresponding GST No.	

- h) **Co-operative Firm:** Registered un-employed Engineers co-operative Societies/Labour Co-operative Societies are required to furnish the following documents.
 - i. Registration Certificate from the Competent Authority of Co-Operation Department, Government of West Bengal.
 - ii. Supporting documents showing area of operation.
 - iii. By-laws duly approved by the Competent Authority of the Co-Operative Department.
 - iv. Name with address and signature of the Present Board of Directors of the Co-operative Society.
 - v. Minutes of last Annual General Meeting and Audit Report of the Co-operative Society withevidence of submission of the same to the concerned Authorities.
- i) If applicable, Certificate of EPF Code, Current ECR, Payment Confirmation Receipt in respect of EPF showing the payment on or before its last date i.e. 15th of the calendar month as per EPF guideline in respect of the bidder.If any agency has no EPF Registration Certificate, he must submit declaration in the format mentioned below:

Declaration on EPF Code

I/We (_____Name and Address of bidder_____), do hereby declare that no EPF Code have been registered under Employees Provident Fund and Miscellaneous Provision Act, 1952 and subsequent Amendment Acts in respect of my Firm/Organization (_____Name and Address of the Firm/Organization_____) and I have not made

any application for such registration till date. I also declare that there is no statutory liability to my/our Firm/ Organization in terms of the said EPF Act.

Signature _____

Date _____

Seal _____

J) Preference: **There will be no price preference to any Quotationer.**

K) Acceptance: **No conditional / Incomplete Quotation will be accepted under any circumstances.**

PART-B

1. Bid shall remain valid for a period of 180 days (One hundred and Eighty days) up to 27/08/2025. Bid validity for a shorter period shall be rejected by the quotation accepting authority as non-responsive.
2. If any Quotationer withdraws his offer before bid validity period without giving any satisfactory explanation for such withdrawals, he may be disqualified for submission of quotation to PAMCL for a minimum period of 1 (One) year and other action will be taken against him.
3. Quotationers, at their own responsibility are encouraged to visit and examine the site of works and its surroundings and obtain all information that may be necessary for preparing the quotation and entering into the contract for the work mentioned in the NIQ, the cost of visiting the site shall be at the quotationer's own expense.
4. The Project Director, Sufal Bangla under Paschimbanga Agri Marketing Corporation Ltd. (PAMCL) reserves the right to cancel this N.I.Q. due to unavoidable circumstances and no claim will be entertained in this respect
5. A) The intending Quotationer shall clearly understand that whatever may be outcome of the present invitation of quotation, no cost of quotation shall be reimbursable by Sufal Bangla.
B) The Project Director, Sufal Bangla under Paschimbanga Agri Marketing Corporation Ltd. (PAMCL) reserves the right to reject any quotation or all quotations without assigning any reason whatsoever.
6. Before issuance of Work Order, the quotation accepting authority may verify the credentials and other documents of the lowest Quotationer if found necessary. After verification, if it is found that such documents submitted by the Lowest Quotationer is either manufactured or false, in that case, Work Order will not be issued in favour of Quotationer under any circumstances and legal action will be taken against him. After verification with any document comes out to be false, the Work Order already issued will be cancelled and expenditure if any incurred will be forfeited, even also the Security Deposit.

Project Director
SUFAL BANGLA

7. **Date & Time Schedule:**

Sl. No.	Particulars	
1.	Date of Publishing of NIQ online through the website	19.02.2025
2.	Date for downloading of Quotation Documents from the website https://wbtenders.gov.in	Start 19.02.2025 at 06.00 PM End 28.02.2025 at 03.00 PM
3.	Date & Time and venue of Pre-bid meeting	24.02.2025 at 12.30 PM at Sufal Bangla, Project Management Unit, 2 nd Floor, Uttarapan Civic Centre, Maniktala, Kol-700054.
4.	Date of submission of Quotation through the website https://wbtenders.gov.in	Start 20.02.2025 at 10.00 AM End 28.02.2025 at 03.00 PM
5.	Date, Time and Place of Opening of Technical Bid (as and when applicable) through the website https://wbtenders.gov.in	03.03.2025 at 01.00 PM or onwards at Sufal Bangla, Project Management Unit, 2 nd Floor, Uttarapan Civic Centre, Maniktala, Kol-700054
6.	Date of uploading the final list of Technically Qualified Bidders (as and when applicable) through the website https://wbtenders.gov.in at the disposal of appeals, if any	On or after 05.03.2025
7.	Date, Time & place of opening of financial Bid through the website https://wbtenders.gov.in	Date of opening of Financial Bid will be declared at the time of uploading final findings of technical evaluation.
8.	Date of uploading of List of Bidders (as and when applicable) whose financial bid have been opened along with their offered Rates through the website https://wbtenders.gov.in	Will be communicated in due course

8. All Quotationers are informed that presence at office of Project Director, Sufal Bangla during opening the quotation to observe the quotation opening procedure is not mandatory. Project Director, Sufal Bangla under PAMCL may call Open Bid/Sealed Bid after opening the said quotation to obtain the suitable rate further, if it is required and no objection in this respect will be entertained if raised by any Quotationer who will be absent at the time of opening of quotation. No informal quotation will be entertained in the Bid further.
9. **Earnest Money:** Earnest Money (without any interest) of the entrusted agency will be refunded after successful delivery of vehicles with all works as detailed in this document completed.
10. Tax invoice(s) needs to be issued by the contractor for raising claim under the contract showing separately the tax charged in accordance with the provisions of GST Act, 2017.
11. In case of ascertaining Authority at any stage of application or execution of work necessary registered power of attorney is to be produced.
12. In any case in which under any clause/clauses of this contract the contractor shall have rendered himself liable to pay compensation amounting to the whole of his security deposit the concerned Authority on behalf of the Project Director, Sufal Bangla under PAMCL shall have power to adopt any of the following courses as he may deem best suited to the interests of the works.

The authority of Sufal Bangla may rescind the contract (of which recession notice in writing to the contractor under the hand of the concerned authority shall be conclusive evidence) and in which case the security deposit of the contractor shall stand forfeited, and will be absolutely at the disposal of Sufal Bangla under Paschimbanga Agri-Marketing Corporation Ltd.

 Project Director
SUFAL BANGLA

13. Arbitration will not be allowed for the settlement of any dispute between parties

14. **Security Deposit:** The successful bidder shall have to submit Security Deposit (SD) @ 10% of the total Quoted value in the form of Bank Guarantee (BG) from any scheduled bank before execution of the Agreement. Applicability of Additional Performance Security will be guided by the Finance Department, GoWB Order No. 5696-F(Y), Dated : 1.10.2019. Failure to complete the entire work within the stipulated time as prescribed in this Document or to provide satisfactory Service during warranty period, i.e within 6 months from the completion of the entire work would result in forfeiture of SD amount and Additional Performance Security amount to the extent as would be decided by the Authority and the decision of the Authority in this regard shall be binding on the bidder.

15. Liquidated Damages:-

15.1 The Agency shall pay Liquidated Damages (LD) to the Employer @ 0.5% of the proportionate value of residual work as on date of imposing LD per week or part thereof for the period that the actual Completion Date is later than the Intended Completion Date. The total amount of LD shall not exceed 10% (ten percent) of proportionate value of residual work. The Employer/TIA may deduct LD from payments due to the Contractor. Payment of liquidated damages shall not affect the Contractor's other liabilities.

15.2 If the amount of liquidated damages exceeds 10% of residual value of work, the contract will be terminated forthwith .

16. Dispute Redressal System:-

Except where otherwise provided in the contract all questions and disputes relating to the meaning of the specifications and instructions herein before mentioned and as to the quality of workmanship or materials used on the work or as to any other question, claim, right, matter or thing whatsoever, in any way arising out of relating to the contracts specifications, estimates, instructions, orders or these conditions or otherwise concerning the works, or the executions or failure to execute the same, whether arising during the progress of the work, or after the completion or abandonment thereof shall be dealt with as mentioned hereinafter.

If the contractor considers any work demanded of him to be outside the requirements of the contract, or disputes any, record or decision given in writing by the Engineer-in-Charge on any matter in connection with or arising out of the contract or carrying out of the work, to be unacceptable, he shall promptly within 15 days request the Chairman of the Dispute Redressal Committee in writing for written instruction or decision. Thereupon, the Dispute Redressal Committee shall give its written instructions or decision with a period of three months from the date of receipt of the contractor's letter.

Either party will have the right of appeal, against the decision of the competent authority, to the Standing Empowered Committee if the amount appealed against exceeds rupees one lakh.

The Standing Empowered Committee to meet up the dispute in each of the Works under dispute shall be constituted with the following officials as members –

1	Additional Chief Secretary / Principal Secretary / Secretary of the Department concerned	Chairman
2	Engineer-in-Chief / Chief or any officer of Engineer equivalent rank of the Department	Member
3	One Designated Chief Engineer / Engineer of the Department to be nominated by the Department concerned	Member Secretary and Convenor

+

4	One representative of Finance Department of the Government not below the rank of Joint Secretary or Financial Adviser in case of the works Department where FA system has been introduced	Member
---	---	--------

The Contractor and the Employer will be entitled to present their case in writing duly supported by documents. If so requested, the Standing Empowered Committee may allow one opportunity to the Contractor and the Employer for oral arguments for a specified period. The Empowered Committee shall give its decision within a period of ninety days from the date of appeal, failing which the contractor can approach the appropriate court for the resolution of the dispute.

The decision of the Standing Empowered Committee will be binding on the Employer for payment of claims upto five percent of the Initial Contract Price. The Contractor can accept and receive payment after signing as "infull and final settlement of all claims". If he does not accept the decision, he is not barred from approaching the courts. Similarly, if the Employer does not accept the decision of the Standing Empowered Committee above the limit of five percent of the Initial Contract Price, he will be free to approach the courts applicable under the law.

17. Cost of escalation for any materials, labour, time loss etc. will not be allowed under any circumstances.
18. Canvassing in connection with the quotation is strictly prohibited in the Quotation submitted by the Contractor.
19. The successful Quotationer will have to submit two sets of all the Quotation Documents in hard copy within 7 (Seven) days from the date of receipt of Letter of Acceptance of the Quotation (through e-Quotating System or otherwise). Failure to do so will be liable to termination/rejection of Quotation with forfeiture of Earnest Money without any reference to the Contractor. In case of the successful Quotationer who has been exempted from depositing Earnest Money, the Government will be at liberty to recover the forfeited amount (equal to the amount of Earnest Money) either from the Fixed Security Deposit of the Quotationer or by any means that may be deemed suitable.
20. The successful Quotationer will have to start the work as per the work order to commence the work.
21. Successful Quotationer will be required to obtain valid Registration Certificate & Labour License from respective Regional Labour Offices where work by them is proposed to be carried out under the West Bengal Building & other Construction Works' Act, 1996 and the Contract Labour (Regulation & Abolition) Act, 1970 and the same should be submitted to the Engineer in Charge.
22. The successful Quotationer shall have to comply with the provision of (a) the Contract Labour (Regulation & Abolition) Act, 1970 (b) the Apprentice Act, 1961 and (c) the Minimum Wages Act, 1948 (d) the West Bengal Building & other Construction Works' Act, 1966 and the Notifications thereof or other laws relating thereto and the rules made and orders issued there under from time to time, failure to do so will be treated as breach of contract and the Employer may in his discretion cancel the contract. The contractor shall also be liable for any liability arising on account of any violation by him of the provisions of the Act and rules made there under time to time.
23. The contractor shall not be entitled for any compensation for any loss suffered by him.
24. Prevailing safety norms has to be followed by the successful Quotationer during execution of the work so that LTI (Loss of time due to injury) is zero.
25. The eligibility of a Quotationer will be ascertained on the basis of the documents submitted by a Quotationer in support of eligibility criteria. If any document submitted by a Quotationer is incorrect / manufactured /

fabricated or false, his Quotation will be outrightly rejected at any stage with forfeiture of Earnest Money. Besides, the bidder may be debarred from participating in further quotation under this Organization for such period as may be decided by the authority and legal action may also be taken against him.

26. If any bidder has been found involved in any fraudulence practice with Central Govt/State Govt/ State Govt PSU/Central Govt. PSU) during last 5 years, his bid will be outrightly rejected and the agency will be declared as disqualified.



**Project Director
SUFAL BANGLA**

**Project Director
SUFAL BANGLA**

Section 3
Qualification Information

DOCUMENTS FOR TECHNICAL BID

Name of Quotationer:.....

Address of Quotationer:.....

Contact No (s): Tele No..... Mob. No.....

Parameters for Technical Evaluation	Status
a) Certificate of Incorporation / Registration and/or Memorandum of article of the agency	
b) GST Registration Certificate	
c) Valid updated Trade License	
d) Professional Tax Registration Certificate, Current Professional Tax Challan Acknowledgement Receipt or current Professional Tax payment Certificate (PTPC).	
e) PAN Card as allotted by the Income Tax Department	
f) Income Tax return for the F.Y 2020-21, 2021-22, 2022-23.	
g) Proof of last Five years' experiences for similar type of jobs in Govt/Govt. Undertaking bodies	
h) If applicable, Certificate of EPF Code. Current ECR, Payment Confirmation Receipt in respect of EPF showing the payment on or before its last date i.e. 15 th of the calendar month as per EPF guideline in respect of the bidder.	

Yours faithfully

(Signature of Quotationer with rubber stamp)

+ _____) _____

Project Director
SUFAL BANGLA

SECTION – 4
FORM-I
QUALIFICATION APPLICATION

To
The Project Director,
Sufal Bangla under Paschimbanga Agri Marketing Corporation Ltd.
2nd Floor, Uttarapan Civic Centre, Maniktala, Kolkata 700 054

Ref:-Quotation for.....
.....(Name of work).....
.....
.....

Dear Sir,

Having examined the pre-qualification documents (N.I.Q.), I /we hereby submit all the necessary information and relevant documents for evaluation.

The application is made by me / us on behalf of
In the capacity.....
Duly authorized to submit the Quotation.

The necessary evidence admissible by law in respect of authority assigned to us on behalf of the group of firms for Application and for completion of the contract documents is attached herewith.
We are interested in bidding for the works given in Enclosure to this letter.

We understand that:

- (a) Employer can amend the scope & value of the contract bid under this project.
- (b) Employer reserves the right to reject any application without assigning any reason;

Encl :-

- 1. Prescribed forms duly filled.
- 2. Evidence of authority to sign.

Date :-

**Signature of applicant including title
and capacity in which application is made.**

Project Director
SUFAL BANGLA

AFFIDAVIT- 'Y'

(To be furnished in Non-judicial Stamp paper of appropriate value duly notarized on or after the date of publication of this NIQ)

I, Sri/Smt. _____, son/daughter of _____, residing at _____, by faith _____, by occupation _____, do hereby solemnly declare and affirm as follows:

1. That neither our firm/company _____ nor any constituent firm/company is debarred to participate in quotation by any organization of Government, Semi-Government, Autonomous Body of Central Government/State Government/West Bengal State Agricultural Marketing Board/Regulated Market Committee/ Sufal Bangla during the last 5 (five) years as on the date of the instant Notice Inviting Quotation.
2. That further qualifying information as may be requested shall be furnished without delay.
3. That I have applied in the Quotation in the capacity of individual/as a partner of the firm/company as a Principal Officer of the firm/company and I have not applied severally for the same job.
4. That all the statements made in the attached documents are true and correct. If any declaration submitted is found/ascertained to be incorrect/fabricated/misrepresented/fraudulent etc. the quotation will be liable to be cancelled/terminated immediately and I/my firm/company shall also be liable to be prosecuted under section 197, 199 and 200 of Indian Penal Code, 1860 (corresponding Section(s) of THE BHARATIYA NYAYA SANHITA, 2023) along with section 71 and section 73 of Indian Information & Technology Act, 2008 and any other applicable law for the time being in force in addition to forfeiture of Earnest Money/Security Deposit.

Signed by _____ Name _____

Designation _____

Name of the firm/company with seal

Date: _____

Note : Affidavit on prior date of NIQ will not be allowed. Additional declaration may be given by the bidder as per necessity and pages of Affidavit inclusive of reverse page should be submitted.

SECTION – 4

FORM-II

STRUCTURE AND ORGANISATION

- A. 1. Name of Applicant (Firm) : Office Address :
- Telephone No. :
Mobile No. :
e-Mail :
- A. 2. Office Address :
- Telephone No. :
Mobile No. :
e-Mail :
- A. 3. Name and address of Bankers :
- A. 4. Attach an Organization chart showing: structure of the company with names of Key personnel and technical staff with Bio-data.

Project Director
SUFAL BANGLA

SECTION_4
FORM-III
EXPERIENCE PROFILE

Name of the Applicant:

LIST OF WORKS COMPLETED WORKS WHICH ARE SIMILAR IN NATURE AND EXECUTED DURING THE LAST FIVE YEARS.

Name of Employer	Name, Location & nature of work	Contract price in Indian Rs.	Original date of start of work	Original date of completion of work	Actual date of starting the work	Actual date of completion the work

Note: a) Certificate from the Employers to be attached.

b) Non-disclosure of any information in the Schedule will result in disqualification of the firm.

Signature of the Quotation



Section 5
Letter of Acceptance

To

.....
.....
.....

This is to inform you that Sufal Bangla under Paschimbanga Agri-Marketing Corporation Ltd has accepted your Bid @ Rs. _____ for executions of the Work "Name of Work _____" vide N.I.Q. No. _____ Dated ___/___/___ against the Awarded Price for ₹ _____/- (Rupees _____) only.

You are hereby requested to make an agreement with SUFAL BANGLA under Paschimbanga Agri-Marketing Corporation Ltd on a non-judicial paper of Rs.100 (Two Sets) by depositing Rs.1,000/- (Rupees One Thousand) only as agreement fees for two sets of documents to the office of the undersigned along with original documents within 7 [Seven] working days from the date of uploading this letter of Acceptance in the e-Tender portal, failing which your bid will be treated as cancelled along with forfeiture of Earnest Money deposited in this respect as applicable.

You have to declare before execution of the agreement that all the materials at the site as per SBD will be arranged by you at the time of execution of work. Non submission of the said declaration before agreement will cause for cancellation of the bid with forfeiture of EMD of the L1 bidder.

You are further requested to submit Security Deposit @ 10% of the total Quoted value in the form of Bank Guarantee (BG) from any scheduled bank before the execution of the Agreement.

You are also requested to submit prescribed particulars mentioned in the enclosed format before execution of the agreement.

Yours faithfully,

Project Director
SUFAL BANGLA

Memo No.

Dated.

Copy forwarded for information and taking necessary action to:

1. Engineering/Accounts Section, Sufal Bangla.
2. Office Copy.

Project Director
SUFAL BANGLA



Project Director
SUFAL BANGLA

Section 6
Instruction to Bidders

1. **The Project Director, Sufal Bangla under Paschimbanga Agri-Marketing Corporation Ltd, invites online Quotations from experienced and resourceful Fabricator who are working as a body builder of goods vehicle and having registered Office within the State of West Bengal for the work "Fabrication of Light Goods Vehicles (LGV)(Mahindra Supro Mini Profit Truck VX BS6.2) (Newly Purchased)"**
2. The interested agencies should submit tender documents according to the formats furnished, complete in all respects through e-Tender portal. Additional documents, if required, may also be sought by the Authority.
3. The Technical Bid, along with '**Qualification Information (Section-3)**', should contain self-attested photo copy of each of the documents mentioned at (a) to (h). Non submission of any of the documents mentioned in the Bid document will render the agency ineligible and its quotation will be rejected. The Financial Bid will not be opened for the disqualified agencies in the Technical Evaluation.
4. Rates will remain firm for the work "Fabrication of Light Goods Vehicles (LGV)(Mahindra Supro Mini Profit Truck VX BS6.2) " for a period of 180 days only. No escalation whatsoever shall be allowed unless otherwise stated in Work Order or subsequent amendment to the Work Order.
5. The authority of Sufal Bangla under Paschimbanga Agri-Marketing Corporation Ltd (PAMCL) will provide cost for the entire work as mentioned and detailed in the SBD and BOQ.
6. The entrusted agencies shall have the duties to maintain all statutory obligations.
7. Sufal Bangla authority shall make all necessary statutory deductions (e.g. TDS on Income Tax under the I.T. Act, 1961 etc.), if applicable, with other necessary adjustments, if required under the contract, against the claim(s) of the agency / successful tenderer.
8. Payment will be made after statutory deductions only after delivery of all complete vehicles as per bid document along with satisfactory certification from the authority in this regard.
9. The Quotation should be unconditional. Imposition of any condition by the Quotationer shall invite cancellation of the quotation.
10. The Earnest Money will be forfeited if
 - (a) The Quotationer withdraws at any stage after taking participation in the quotation till finalization of the quotation.
 - (b) The selected Quotationer fails or refuses to enter into contract within 7 days from the date of issuance of the Letter of Acceptance (LOA) of the tender
 - (c) Selected agency withdraws his bid within the bid validity period
11. On completion of tender procedure, the successful Quotationer will be required to enter into a contract with the authority within 7 days from the date of issuance of Letter of Acceptance (LOA) upon deposit of Security Deposit @ 10% of the total Quoted value in the form of Bank Guarantee (BG) from any scheduled bank. Applicability of Additional Performance Security will be guided by the Finance Department, GoWB Order No. 5696-F(Y), Dated : 1.10.2019..
12. If the services of tenderer are found unsatisfactory, the authority reserves the right of termination of contract of agreement with one month's notice for such.

Project Director
SUFAL BANGLA

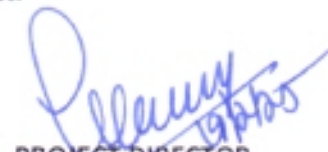
13. Violation of any condition as couched in the contract will render the contract liable to be terminated at any point of time with forfeiture of Security Deposit and Additional Performance Security, if applicable, and may also invite any other punitive measure as the authority may deem fit.
14. Bidder should strictly adhere to the specification mentioned in the bid document. No deviation in the specifications shall be accepted.
15. Bidder should quote for the entire work as mentioned in the Scope of Work and other taxes and charges as applicable. The quoted rate must be inclusive of GST, Transportation cost etc. for the entire work.
16. Registration Certificate of the vehicle is needed in favour of 'Paschimbanga Agri Marketing Corporation Ltd., 1st Floor, Kamal Guha Krishi Bipanan Bhavan, 729, Anandapur, Kolkata-700107, West Bengal'
17. All vehicles, as per the bid document, shall have to be received from and delivered to Sufal Bangla Project Management Unit at Tapashi Malik Krishak Bazar, Singur, Dist. Hooghly, West Bengal.
18. In case of any dispute arising out of this tender, the decision of the Dispute Redressal Committee, in this regard shall be final and binding to all.
19. The Sufal Bangla holds no responsibility/ liability for any injury or accidental injury/ death of any deployed person from awarded agency's end for performing the assigned jobs within agreement of tender.
20. The applicant should quote consolidated rates for such assigned job as mentioned in Section-2 of Notice Inviting e-Quotation.
21. The Project Director, Sufal Bangla under PAMCL reserves the right to amend / withdraw any of the terms and conditions in the Tender Document or to reject any or all the tenders without giving any notice or assigning any reason.
22. The above terms and conditions shall form the part of the agreement of contract.



PROJECT DIRECTOR
SUFAL BANGLA

Project Director
SUFAL BANGLA

Section-7
Standard Form: Agreement

Agreement

This agreement, made the....., between Project Director, Sufal Bangla under Paschimbanga Agri Marketing Corporation Ltd, 2nd Floor, Uttarapan Civic Centre, Maniktala Kol-700054 of the one part and

....., the other part

Whereas the Employer is desirous that the Contractor execute N.I.Q No. Dated.....for the work of "....." and the Employer has accepted the Bid by the Contractor for the execution and completion of such Works and the remedying of any defects therein at a cost of Rs./-

NOW THIS AGREEMENT WITNESSETH as follows:

1. In this Agreement, words and expressions shall have the same meanings as are respectively assigned to them in the Conditions of Contract hereinafter referred to, and they shall be deemed to form and be read and construed as part of this Agreement.
2. In consideration of the payments to be made by the Employer to the Contractor as hereinafter mentioned, the Contractor hereby covenants with the Employer to execute and complete the Works and remedy any defects therein in conformity in all aspects with the provisions of the Contract.
3. The Employer hereby covenants to pay the Contractor in consideration of the execution and completion of the Works and the remedying the defects wherein the Contract Price or such other sum as may become payable under the provisions of the Contract at the times and in the manner prescribed by the Contract.

Project Director
SUFAL BANGLA

4. The following documents shall be deemed to form and be read and construed as part of this Agreement, viz:-

- | | |
|---|-------------------------------------|
| i) Letter of Acceptance; | LOA-.....Dated |
| ii) Notice to proceed with the works; | As immediate as possible |
| iii) Contractor's Bid; | As submitted |
| iv) Contract Data; | of attach Schedule. |
| v) Special Conditions of contract and General Conditions of Contract; | As per specified above E-quotation. |
| vi) Specifications; | Same as above |
| vii) Bill of Quantities; and | As per specified above E-quotation. |

viii) Any other document listed in the Contract Data as forming part of the contract. As when requisition will be submitted.

In witness whereof the parties thereto have caused this Agreement to be executed the day and year first before written.

The Common Seal of

was hereunto affixed in the presence of:

Signed, Sealed and Delivered by the said

in the presence of:

Binding Signature of Employer

Binding Signature of Contractor



Project Director
SUFAL BANGLA

Section – 8

Check List for Bidders

A bidder is to upload the documents below for evaluation of submitted bid:
(A statement showing documents in seriatim is to be uploaded)

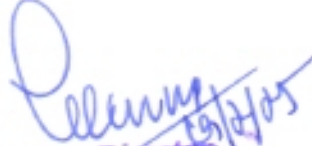
1. For bidders who are individual
 - 1.1. PAN card
2. For Partnership firm :
 - 2.1. Deed of Partnership duly registered.
3. For Companies:
 - 3.1. PAN card
4. For Un-employed Engineers Co-operative Societies / Labour Co-operative Societies:
 - 4.1. PAN card.
 - 4.2. By-laws of the Co-operative society and Registration certificate.
 - 4.3. Name, Address & signature of the present Board of Directors of co-operative Society.
5. For others including Joint Venture/Consortium.
 - 5.1. Duly registered constitution/deed with appropriate Authority.
 - 5.2. PAN card of the constituted body or for all members of the consortium.
 - 5.3. Affidavit Y as prescribed sworn in by all the members of Joint venture/ Consortium.
6. Other documents to be submitted:
 - 6.1. Professional Tax Registration Certificate, Current Professional Tax Challan Acknowledgement Receipt or current Professional Tax payment Certificate (PTPC).
 - 6.2. GST Registration certificate with Latest GST Return.
 - 6.3. Current Income Tax Return acknowledgement issued by I.T. Department.
 - 6.4. Audited Annual Accounts as prescribed for the F.Y 2020-21, 2021-22, 2022-23 and other entities, if turnover exceeds Rs 2.00 crore in a year and ,
 - 6.5. Self-signed Annual Accounts of three consecutive years showing magnitude of similar nature of completed works and work-in-progress (WIP), to be submitted, if turnover does not exceed Rs 2.00 crore in a year.

Project Director
SUFAL BANGLA

7. Documents regarding Credential:
 - 7.1. As detailed in Section-2 .
 - 7.2. Certificate regarding compliance of specification.
8. Duly notarized Affidavit-Y in prescribed form.
9. All Tables and forms as prescribed in the bidding documents are to be filled-in and uploaded.
10. Not applicable Tables and Forms are to be struck out and uploaded.
11. Non submission of any of the applicable documents of this check list would make the submitted bid as non-responsive.
12. Participating bidder will provide a statement indicating documents uploaded in seriatim.

N.B: This list is not exhaustive; the bidders are requested to go through the all provisions of the uploaded Standard Bid Document (SBD) and to follow strictly the matter of uploading all relevant documents wherever necessary to fulfill eligibility criteria.



Project Director
SUFAL BANGLA

SECTION-9

GENERAL INSTRUCTIONS TO BIDDERS

1. Registration of Bidder- Bidders willing to take part in the process of e-tendering will have to be enrolled & registered with the Government e-procurement system through logging on to <https://wbtenders.gov.in>.
2. Digital Signature Certificate (DSC)- Each bidder is required to obtain a Class-III Digital Signature Certificate (DSC) for submission. Details are available at the website <https://wbtenders.gov.in>.
3. DSC once mapped to an account cannot be remapped to any other account. It can only be inactivated.
4. The bidders can update well in advance, the documents such as certificates, purchase order details etc., under " My documents" option and these can be selected as per tender requirements and then attached along with bid documents during bid submission. This will ensure lesser upload of bid documents.
5. After downloading/getting the tender schedules, the bidder should go through them carefully and then submit the documents as per the tender documents, otherwise, the bid will be rejected.
6. The BOQ must not be modified/replaced by the bidder and the same should be uploaded after filling the relevant columns, else the bidder is liable to be rejected for that tender. Bidders are allowed to enter the Bidder name and values only.
7. Bidder, in advance, should prepare the bid documents to be submitted as indicated in the tender schedule and they should be in PDF formats with minimum file size as per Memo. No. 6770-F(y) Dated 26th December, 2023. If there is more than one document, they can be clubbed together.
8. The bidder has to submit the tender document(s) online well in advance before the prescribed time to avoid any delay or problem during the bid submission process.
9. The size of file uploaded at the server end should be of minimum size. However, the upload is decided on the memory available at the client side at that point of time. In order to reduce the file size, bidders are suggested to scan the documents in 150 DPI as per Memo. No. 6770-F(y) Dated 26th December, 2023, so that the clarity is maintained and also the size of file also gets reduced. This will help in quick uploading even at very low bandwidth's speed.
10. It is important to note that, the bidder has to click on the Freeze Bid button, to ensure that he/she completes the Bid submission process. Bids which are not frozen are considered as incomplete/invalid bids and are not considered for evaluation process.

11. The Tender Inviting Authority (TIA) will not be held responsible for any sort of delay or the difficulties faced during the submission of bids online by the bidders due to local issues.
12. After the bid submission, the bid summary has to be printed and kept as an acknowledgement as a token of the submission of the bid. The bid summary will act as a proof of bid submission for a tender floated and will also act as an entry point to participate in the bid opening event.
13. The bidder should see that the bid documents submitted should be free from virus and if the documents could not be opened, due to virus, during tender opening, the bid is liable to be rejected.
14. The bidders are requested to submit the bids through online e-Procurement system to the TIA well before the bid submission end date and time (as per server system clock).
15. Bidders are also advised to submit EMD of their bid, at least 3 working days before the bid submission closing date as it requires time for processing of Payment of EMD.
16. Bidders eligible for exemption of EMD as per Govt. rule may avail the same and necessary documents and relevant Government Order(s) regarding the exemption of EMD must be uploaded in the EMD folder of Statuary bid documents.

Project Director
SUFAL BANGLA

DISCLAIMER

This document has been prepared by Sufal Bangla, a project under Paschimbanga Agri Marketing Corporation Ltd under the Department of Agricultural Marketing, Government of West Bengal. The information is provided to the prospective bidders purely to enable them to bid for the proposal. The proposal is neither an agreement with any party nor invitation to any party to perform work of any kind. While this office has taken due care in the preparation of the information contained herein. This office doesn't claim that the information is exhaustive. Respondents to this Proposal are required to make their own inquiries and they should not rely solely upon the information in this proposal. This office is not responsible if no due diligence is performed by the respondents. The undersigned reserves the right not to proceed with this proposal, accept or reject any proposal, annul the process and reject all proposals, to alter the time-table as reflected in this document or to change the process or procedure to be applied at any time prior to contract award without thereby incurring any liability to bidders or assigning any reason thereof. It also reserves the right to decline to discuss the proposal further with any respondent. No reimbursement of cost of any type or on any account will be paid to persons or entities submitting their bid. In case of any inadvertent typing error found in the Standard Bidding Document, it shall be interpreted keeping in conformity with the context of the SBD. Points that have not been mentioned in this Standard Biding Document shall be interpreted as per the existing financial rules of the Govt. of West Bengal.

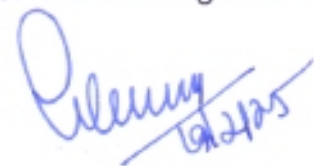

PROJECT DIRECTOR

SUFAL BANGLA



West Bengal State Agricultural Marketing Board

[A Statutory Body under Agricultural Marketing Department, Government of West Bengal]

'Kamal Guha Krishi Bipanan Bhawan'

729, Anandapur, Kolkata 700 107 West Bengal, Phone: (+91) 9147133228

Website: wbagrmarketingboard.gov.in // Email: wbstatemarketing@yahoo.co.in

Memo No. 553/EC/Gen/32/25 dated 19/02/2025

To
The Project Director
SUFAL BANGLA
Project Management Unit
2nd Floor, Uttarapan Civic Centre
Maniktala, Kolkata 700 054.

Sub : Vetting of Estimate

Ref : No. 99-502/EPDC/SB/2024 (Part) Dated 18/02/2025

In connection with the subject under reference the estimate for the following work duly vetted by the competent authority is being sent to him for doing the needful.

Sl. No.	Name of the Project	Vetted Cost	Vetted by
1.	Canopy Structure on Mahindra Supro Mini Profit Truck	Rs.9,59,713.00	Project Engineer, West Bengal State Agricultural Marketing Board

Encl : Vetted Estimate.

Memo No. 553/EC/Gen/32/25

Copy forwarded for information and taking necessary action to :

1. Managing Director, Paschimbanga Agri Marketing Corporation Ltd.
2. Engineering Cell, West Bengal State Agricultural Marketing Board.

Chief Executive Officer

Dated 19/02/2025

Chief Executive Officer

Sumit
19/2/25

Estimate of Canopy Structure on Mahindra Supro Profit Truck

Sl. No.	Schedule Item No.	Description of Item	Unit	Nos.	L	B	H	Qty.	Rate (Rs.)	Amount (Rs.)
1	Ref. item no-2A.I.a. page no-101 of Sch.3rd corrigenda. PWD Schedule 2017	M.S. structural works with hollow sections (square or rectangular shape) conforming to IS: 806-1957 & IS: 1161-1958) connected to one another with bracket, gusset, cleat as per design, drawing & direction of Engineer-in-Charge complete including cutting to requisite shape & size, fabrication including metal arc welding conforming to IS: 816-1956 & IS: 9595 using electrodes of approved make and brand conforming to lengthwise (Size: 25 x 25, unit weight: 1.38 kg/m)								
			Kg					91.74	72.316	6634.27
2	Ref. item no-1(a) page no-200 of PWD Building Sch.	(a) Priming one coat on steel or other metal surface with synthetic oil bound primer of approved quality including smoothening surfaces by sand papering etc.								
		Red oxide Primer	Sq.m					18.25	29	529.25
3	Ref. item no-2(b)(iv) page no-201 of PWD Building Sch.	A) Painting with best quality synthetic enamel paint of approved make and brand including smoothening surface by sand papering etc. including using of approved putty etc. on the surface, if necessary :								
		Paint						18.25	79	1441.75
4		Transportation charges (approx)								7500
Sub-Total cost for Single Vehicle										16105.27
Sub-Total cost for 50 (fifty) nos. of Vehicles										805263
B	add GST 18%									144947
C	Cost of work excluding labour welfare cess									950211
D	Labour welfare cess @1%									9502.11
E	Cost of work including labour welfare cess									959713.0
F	Grand Total									959713
(Total Rupees nine lakh fifty nine thousand seven hundred thirteen) only										

Balyabashi Sankar
12/02/2025
Sub-Assistant Engineer
Paschim Banga Agri Marketing Corporation Ltd.

S. Mitra
13/02/2025
Assistant Engineer (CIVIL)
W.B.S.A.M.B.

Vetted estimate stands Rs. 9,59,713.00 (Rupees Nine lakh fifty nine thousand seven hundred thirteen only)

VETTED

Project Engineer
West Bengal State Agricultural Marketing Board

Drawing & Design of Canopy Structure

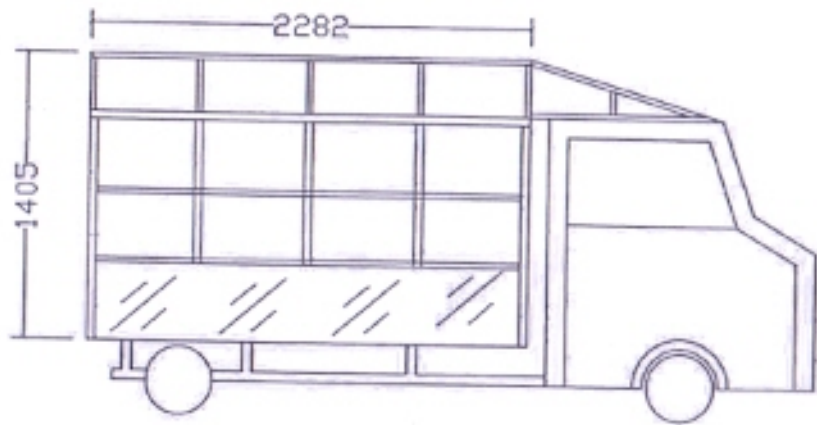

SIDE ELEVATION

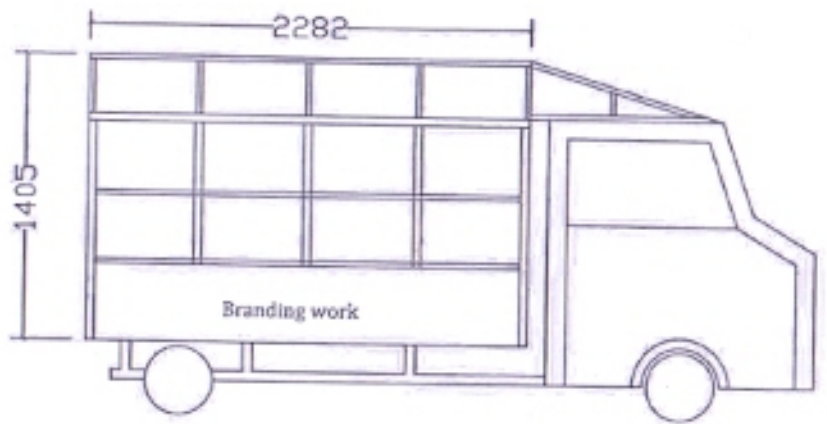

SIDE ELEVATION

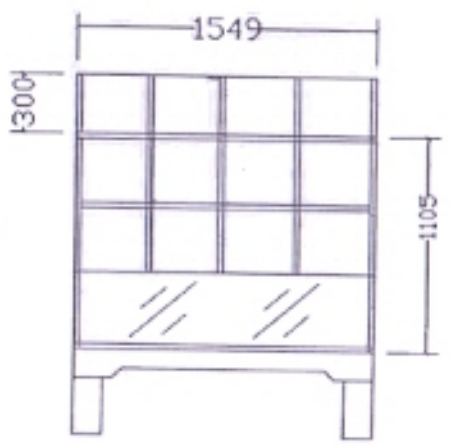

BACK ELEVATION

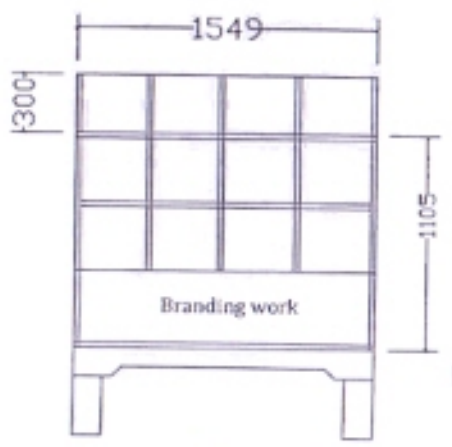

BACK ELEVATION

Sufal Bangla
 Project Director
 SUFAL BANGLA

S. Mitra
 Project Engineer
 West Bengal State Agricultural
 Marketing Board

Sabyasachi Banerjee
 18/02/2025
 Sub-Assistant Engineer
 Paschimbanga Agri Marketing
 Corporation Ltd.

Item Rate BoQ

Tender Inviting Authority: Project Director, Sufal Bangla

Name of Work: Fabrication of Light Goods Vehicles (LGV)(Mahindra Supro Mini Profit Truck VX BS 6.2) (Newly Purchased)

Contract No: PD/PMU/SB/78/2024-25 Dated: 19.02.2025

Name of the Bidder/ Bidding Firm / Company :	
--	--

PRICE SCHEDULE

(This BOQ template must not be modified/replaced by the bidder and the same should be uploaded after filling the relevant columns, else the bidder is liable to be rejected for this tender. Bidders are allowed to enter the Bidder Name and Values only)

NUMBER #	TEXT #	TEXT #	NUMBER #	TEXT #	NUMBER	NUMBER #	NUMBER #	TEXT #
SL No.	Item Description	Item Code / Make	Quantity of Vehicle	Units	Estimated Cost for the entire work for 50 Vehicles in Rs. P	BASIC RATE in Figures To be entered by the Bidder Rs. P	TOTAL AMOUNT in Rs. P	TOTAL AMOUNT in Words
1	2	3	4	5	6	7	8	10
1	Description of work	Item1						
2	(j)M.S. structural works with hollow sections (i) Priming one coat on steel or other metal surface with synthetic oil bound primer of approved quality including smoothening surfaces by sand papering etc (ii) Painting with best quality synthetic enamel paint of approved make and brand including smoothening surface by sand papering etc. including using of approved putty etc. on the surface, if necessary (v)To and fro Transportation of Vehicles For details of work and drawing , please see Annexure-A (Cost of work for one vehicle is to be entered in the specified box)	Item2	50.000	Nos	959713.00		0.00	INR Zero Only
Total in Figures							0.00	INR Zero Only
Quoted Rate in Words								INR Zero Only

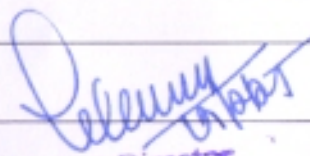
 Project Director
SUFAL BANGLA